

CombiTherm

CENTRIFUGAL PUMP FOR THERMAL OIL / HOT WATER APPLICATIONS

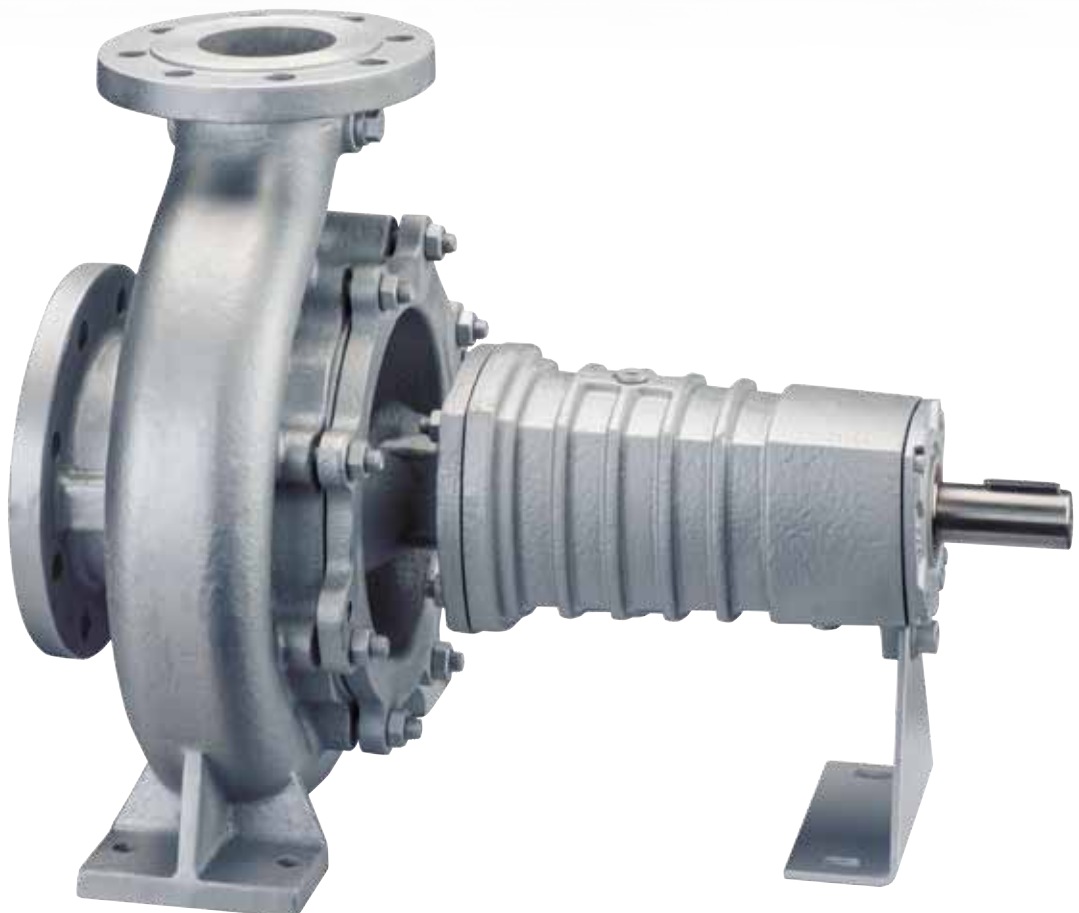

The SPX Johnson Pump CombiTherm is developed especially for thermal oil (DIN 4754) and hot water applications EN12953-6 (DIN 4752) (ratings and dimensions to EN733 (DIN24255)). CombiTherm ensures uniform process temperatures while keeping damaging heat away from seal faces and bearings. CombiTherm is designed to require no external cooling when working within the given parameters. The throttle bush, journal bearing and seal placement reduce circulation and temperature along the pump length. This greatly reduces the temperature at the seal face and bearings. Typical liquid temperatures of 250°C (482°F) at the pump inlet will be as low as 100°C (212°F) at the seal faces.

The CombiTherm is developed around the well known Combi Modular system. Our modular design provides for maximum interchangeability of components between the variants and also with other pump types of the Combi system; thereby greatly limiting the number of spare parts to be kept in stock.

SPX also offers a full line of filters, valves and heat exchangers.

Based in Charlotte, North Carolina, SPX Corporation (NYSE: SPW) is a global, multi-industry manufacturing leader with operations in more than 35 countries. The company's highly-specialized, engineered products and technologies are concentrated in Flow Technology and energy infrastructure. Many of SPX's innovative solutions are playing a role in helping to meet rising global demand for electricity and processed foods and beverages, particularly in emerging markets.

The company's products include food processing systems for the food and beverage industry, critical Flow components for oil and gas processing, power transformers for utility companies, and cooling systems for power plants. For more information, please visit www.spx.com

MATERIALS

- Nodular cast iron in the pump casing and mechanical seal cover
- 17% hardened chrome steel shaft for increased strength and durability

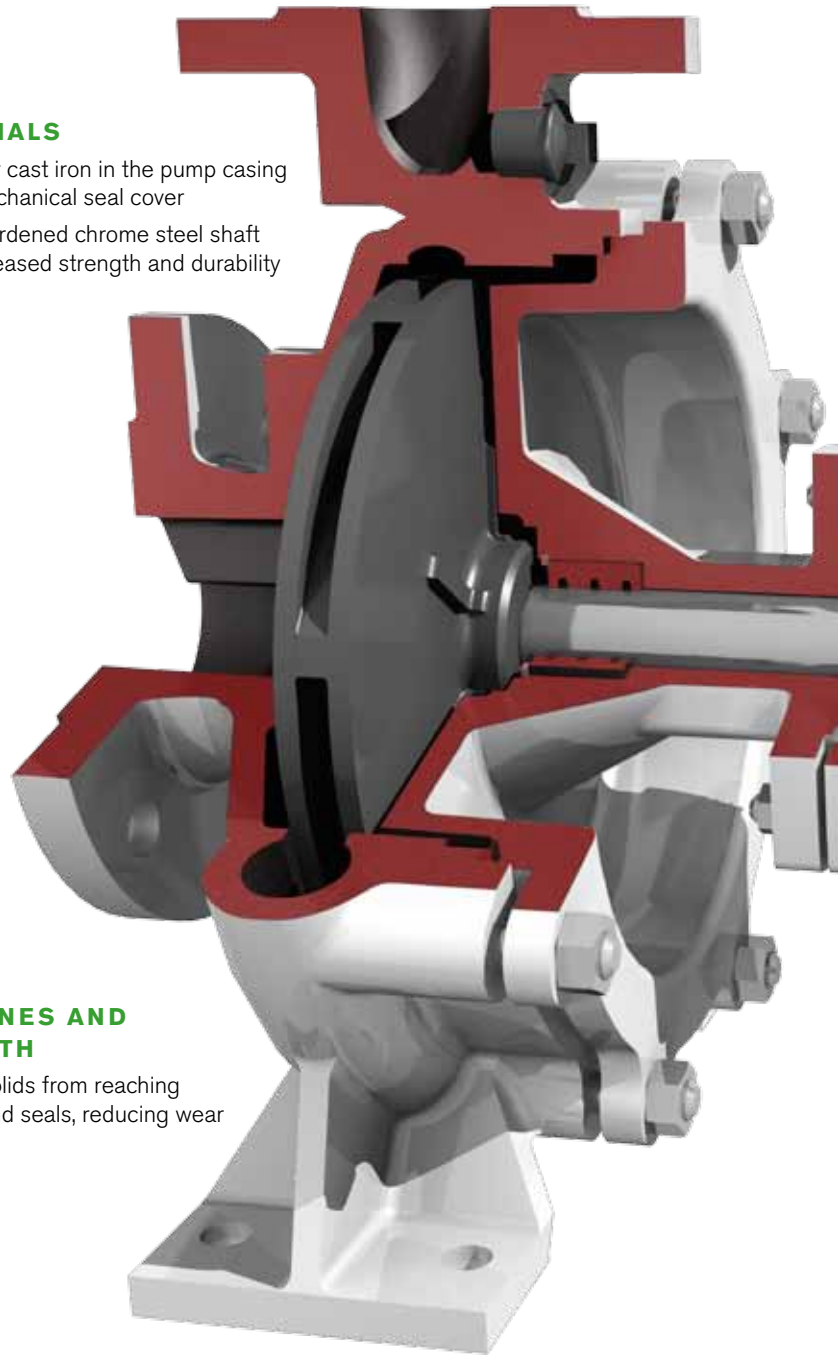

BACK VANES AND LABYRINTH

- Prevent solids from reaching bearing and seals, reducing wear

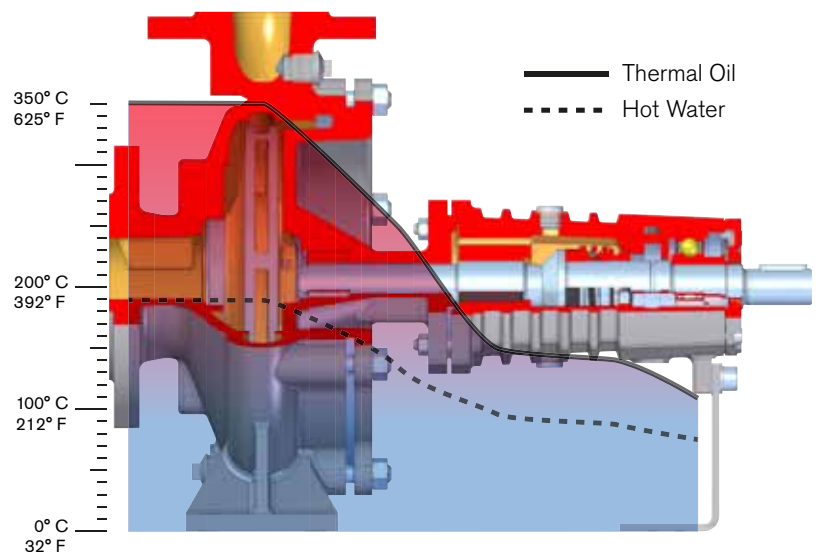

Typical temperature variations along a CombiTherm, dropping from a maximum of 350°C (625°F) at the impeller to a manageable 150–140°C (284–302°F) at the seal chamber and 110°C (230°F) at the bearings.

CombiTherm Circulation pump for Thermal Oil and Hot Water applications

SLIDE BEARING

- Product lubricated

STANDARD MECHANICAL SEAL

- Seal selection according to temperature of pumped liquid
- Optimized for long life
- No external cooling required

ROLLER BEARINGS

- Permanently greased, maintenance free
- Deep-groove ball-bearing or a double-row angular contact ball-bearing

LONG COOLING LENGTH AND COOLING VANES

- Seal removed from immediate contact with the pumped liquid
- Allows heat from the pumped liquid to dissipate before reaching and damaging seal and bearings

EASY MAINTENANCE

- Back Pull-Out design; no need to remove pump from piping

Technical data

Maximum capacity:	350 m ³ /h (1541 GPM) [50 Hz] 400 m ³ /h (1761 GPM) [60 Hz]
Maximum delivery head:	110 m (361 ft) [50 Hz] 160 m (525 ft) [60 Hz]
Maximum liquid temperature:	Thermal oil 350°C (662°F), Hot water 190°C (374°F)
Maximum operating pressure:	16 bar (232 psi)
Maximum speed:	3600 rpm

MATERIAL	
PUMP CASING	NODULAR CAST IRON
IMPELLER, WEAR RING	CAST IRON OR STAINLESS STEEL
MECHANICAL SEAL COVER	NODULAR CAST IRON
PUMP SHAFT	17% CHROME STEEL
MECHANICAL SEAL MATERIAL	CARBON/CRMO-STEEL OR CARBON/SIC

Typical product applications

THERMAL OIL HEAT TRANSFER

OEM systems, maintaining temperature in jacketed equipment



MARINE AND FLOATING PRODUCTION SYSTEMS

Fuel tank heaters and fuel preheating, cargo and product heating, steam generation



Food

Ovens, fish frying, distillation of fatty acids and glycerine, fat softening, potato chips, milk powder plants



BITUMEN

Asphalt production, roads and roofing



RUBBER AND PLASTICS

Injection molding, PVC tape, manmade fibers



CHEMICAL

Agitators, reactors, drying plants, polymerisation, plastics

PAPER AND WOOD

Calender rolls, cardboard, washing machines, driers, floor board and wood panel

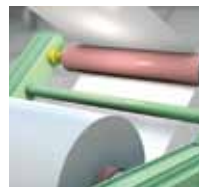

HIGH TEMPERATURE HOT WATER CIRCULATION

Hospitals, heating systems





Thermal Oil & Hot Water
Applications

Dimensions

CAD dimensional drawings available on request.

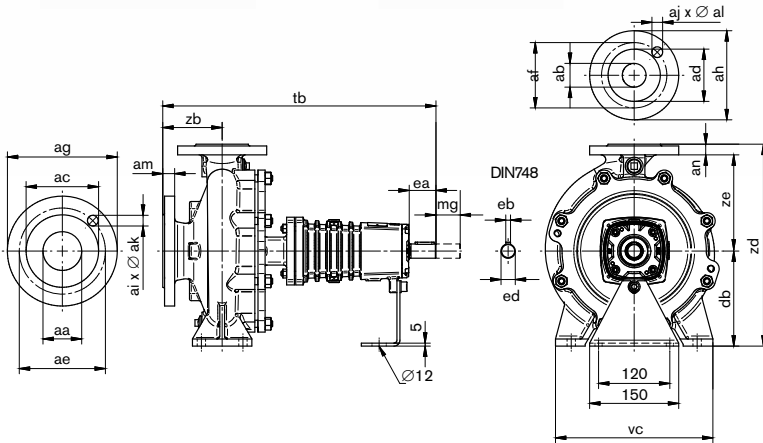

measurements in mm unless specified otherwise

CT	aa	ab	db	ea	eb	ed	mg	tb	vc	zb	zd	ze	[KG]
32(C)-160	50	32	132	45	8	24	100	440	240	80	292	160	35
32(C)-200	50	32	160	45	8	24	100	440	240	80	340	180	40
32-250	50	32	180	45	8	24	100	460	320	100	405	225	61
40C-160	65	40	132	45	8	24	100	440	240	80	292	160	37
40C-200	65	40	160	45	8	24	100	460	265	100	340	180	44
40-250	65	40	180	45	8	24	100	460	320	100	405	225	53
50C-160	65	50	160	45	8	24	100	460	265	100	340	180	40
50C-200	65	50	160	45	8	24	100	460	265	100	360	200	45
50C-250	65	50	180	45	8	24	100	460	320	100	405	225	56
65C-160	80	65	160	45	8	24	100	460	280	100	360	200	45
65C-200	80	65	180	45	8	24	140	460	320	100	405	225	52
65A-250	80	65	200	75	10	32	140	570	360	100	450	250	80
80C-160	100	80	180	45	8	24	140	485	320	125	405	225	53
80C-200	100	80	180	75	10	32	140	595	345	125	430	250	72
80C-250	100	80	200	75	10	32	140	595	400	125	480	280	86
100-160	125	100	200	75	10	32	100	595	360	125	515	315	88
100C-200	125	100	200	75	10	32	140	595	360	125	480	280	99
100C-250	125	100	225	75	10	32	140	610	400	140	505	280	97
125-250	150	125	250	75	10	32	140	610	400	140	605	355	123

FLANGES ACCORDING TO ISO 7005 PN16 ≅ EN1092-2

aa	ab	ac	ad	ae	af	ag	ah	ai x ak	aj x al	am	an
50	32	102	78	125	100	165	140	4 X 18	4 X 18	20	18
65	40	122	88	145	110	185	150	4 X 18	4 X 18	20	18
65	50	122	102	145	125	185	165	4 X 18	4 X 18	20	20
80	65	138	122	160	145	200	185	4 X 18	4 X 18	22	20
100	80	158	138	180	160	220	200	8 X 18	8 X 18	22	22
125	100	188	158	210	180	250	220	8 X 18	8 X 18	24	22
150	125	212	188	240	210	285	250	8 X 23	8 X 18	24	24

FLANGES ACC. TO ISO 7005 PN16/ASME B16.5 150 LBS DRILLED (ANSI 150LBS)

aa*	ab*	ac*	ad*	ae*	af*	ag*	ah*	ai x ak*	aj x al*	am*	an*
1.97	1.26	3.62	2.50	4.75	3.50	6.50	5.51	4 X ¾	4 X ¾	0.79	0.71
2.56	1.57	4.12	2.88	5.50	3.88	7.28	5.91	4 X ¾	4 X ¾	0.79	0.71
2.56	1.97	4.12	3.62	5.50	4.75	7.28	6.50	4 X ¾	4 X ¾	0.79	0.79
3.15	2.56	5.00	4.12	6.00	5.50	7.87	7.28	4 X ¾	4 X ¾	0.87	0.79
3.94	3.15	6.19	5.00	7.50	6.00	8.66	7.87	8 X ¾	4 X ¾	0.87	0.87
4.92	3.94	7.31	6.19	8.50	7.50	9.84	8.66	8 X ¾	8 X ¾	0.94	0.87
5.91	4.92	8.50	7.31	9.50	8.50	11.22	9.84	8 X ¾	8 X ¾	0.94	0.94

*inches

NB! ASME flanges available only in the Americas and the Asian/Pacific areas

SPX FLOW TECHNOLOGY ASSEN B.V.

Dr. A.F. Philipsweg 51, 9403 AD Assen
P.O. Box 9, 9400 AA Assen, THE NETHERLANDS
P: +31 (0)592 37 67 67
F: +31 (0)592 37 67 60
E: johnson-pump.nl.support@spx.com

FOR YOUR LOCAL REPRESENTATIVE:

<http://www.spx.com/en/johnson-pump/where-to-buy/>

SPX reserves the right to incorporate our latest design and material changes without notice or obligation.

Design features, materials of construction and dimensional data, as described in this bulletin, are provided for your information only and should not be relied upon unless confirmed in writing. Please contact your local sales representative for product availability in your region. For more information visit www.spx.com and www.johnson-pump.com.

The green ">" is a trademark of SPX Corporation, Inc.

JP_419_GB Version: 01/2014 Issued: 07/2014

COPYRIGHT © 2014 SPX Corporation